

Installation Instructions

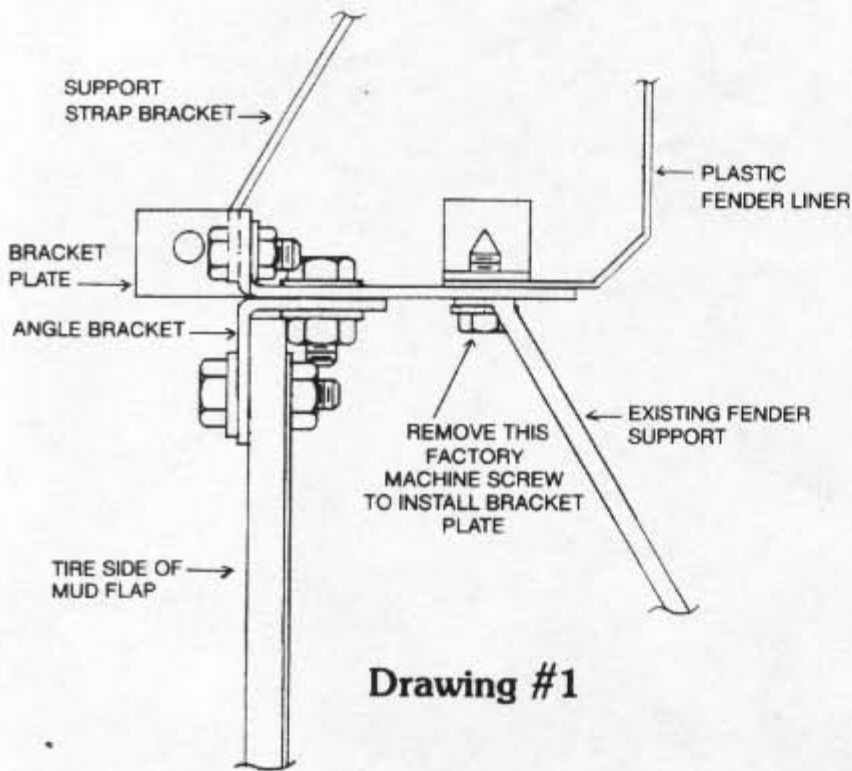

1. Attach angle bracket to mud flap using 5/16" fasteners. You may have to drill through rubber flap where indentions are.

2. Attach bracket plate to angle bracket using 5/16" fasteners.

3. Reach up in rear of wheel well and remove the machine screw that holds plastic liner. See Photo #1 for that location.

4. Remove the machine screw shown in Drawing #1. This screw holds a factory fender support and the bottom of the plastic fender liner. The bracket plate will install at this location.

5. Attach support strap bracket to bracket plate using 5/16" fasteners.

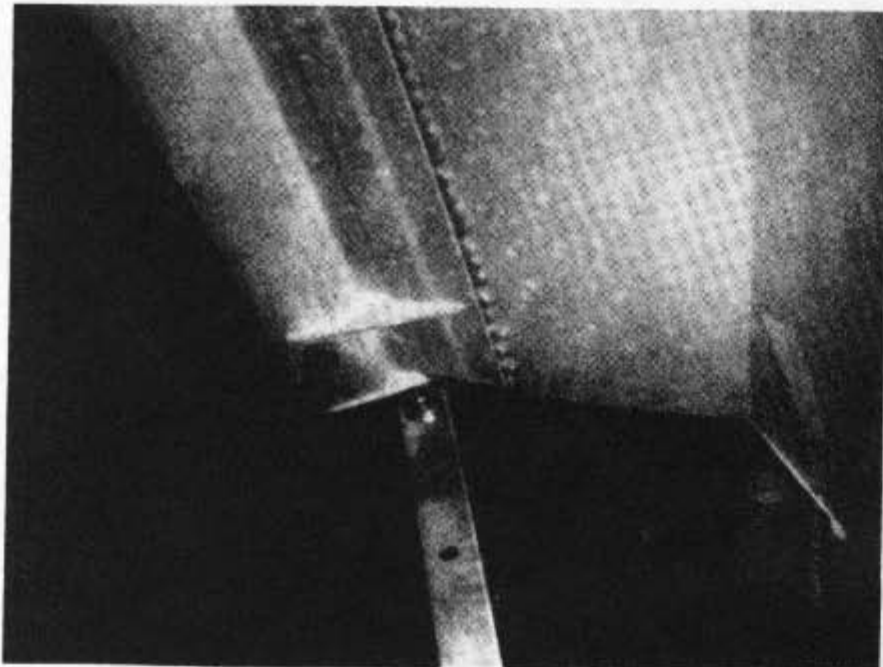
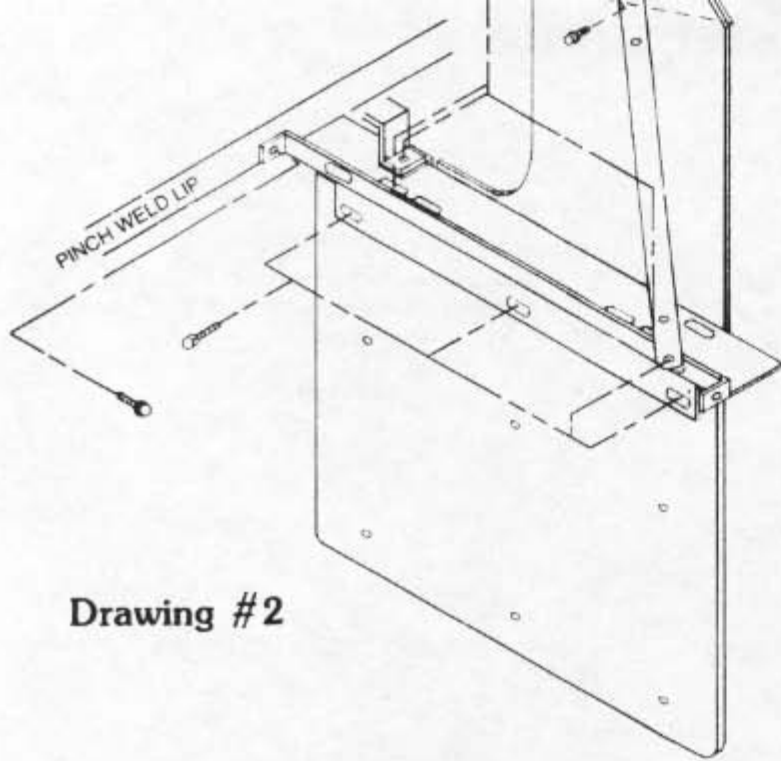

Photo #1



Drawing #2

6. Hold the assembled flap up in wheel well. Make sure the ear at end of bracket plate is against the pinch weld lip under the bed. Re-install the factory machine screw through existing fender support, bracket plate and plastic fender liner. See Drawing #2.

7. Re-install the factory machine screw at top of fender liner attaching support strap bracket at this location. See Drawing #2.

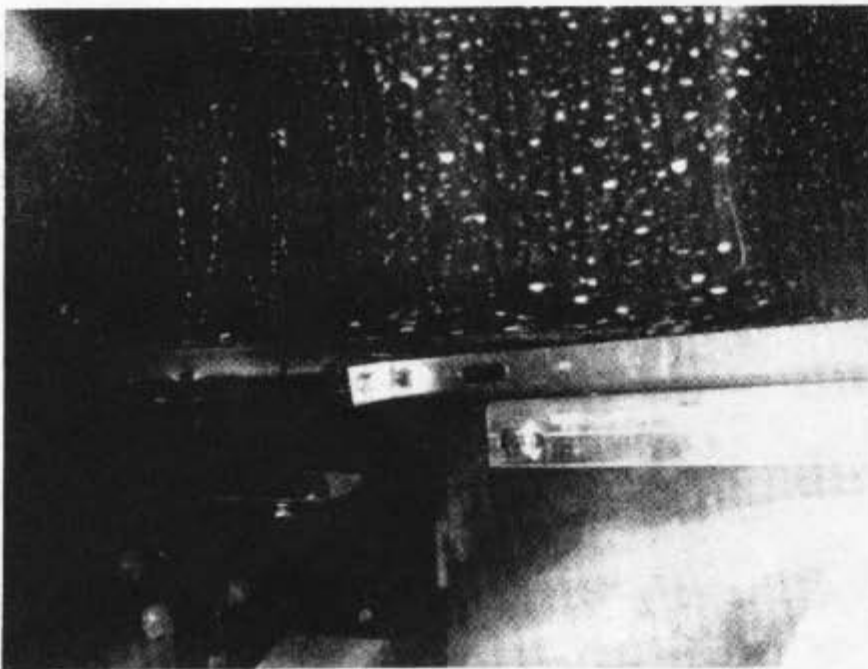

Photo #2

8. Using the hole in bracket plate that is against the pinch weld lip as a guide, drill a 1/8" hole through the lip. Fasten bracket plate and lip together using #14 self threading machine screw we have provided. See Photo #2.

LUND

Lund International

800-241-7219 • Visit us at lundinternational.com

© 2012 Lund International, Inc. All rights reserved.

Lund® and the Lund® logo are trademarks of Lund International, Inc.

